

Twin Gravimetric Dosing Unit

MCS Regrind



Reusing rejects and sprues in the form of regrind can result in saving substantial amounts of colorant. The secret? Dosing masterbatch, powder, liquid or another additive and regrind simultaneously.

One dosing unit of the MCS Regrind functions as the master unit and doses regrind, while the second operates in conjunction with the master unit and doses the additive. In practice this means that the more regrind is available, the less colourant is added. This enables you to avoid over-consumption of additives and to reuse the maximum of regrind. The process is fully automatic, so you always dose the maximum percentage of available regrind.

The quality remains constant, production run after production run, 24/7.

The MCS Regrind uses Movacolor's gravimetric dosing technology. This means continuous loss-in-weight measurement and automatic adjustment. The functionality of dosing regrind in combination with the additive makes the MCS Regrind a sustainable solution for your production process.

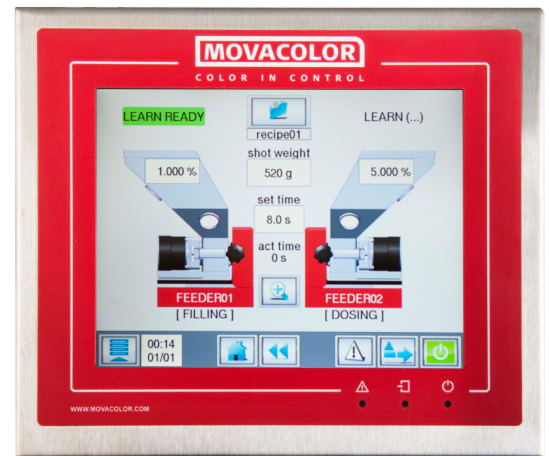

Easy to Install

The in-line dosing units with integrated hopper loaders have a low building height and can always be installed directly on top of your machine.

Full Flexibility

The unique modular system gives you the opportunity to add extra units in the future, depending on the material and the production process.

Small Footprint

With the closed loop function, the sprues from the injection moulding process are directly fed back into the process. No big intermediate storage hoppers are required. The amount of colourant added is automatically adjusted to the availability of regrind.

Features

- ▶ Continuous loss-in-weight measuring
- ▶ Automatic colouring correction depending on recycle material
- ▶ Ultra compact three component system
- ▶ Direct mounting on machine throat
- ▶ 8" full colour touch screen
- ▶ Integrated hopper loader control

Twin Gravimetric Dosing Unit - MCS Regrind



Dimensions MCS Regrind with ME Hopper Loader

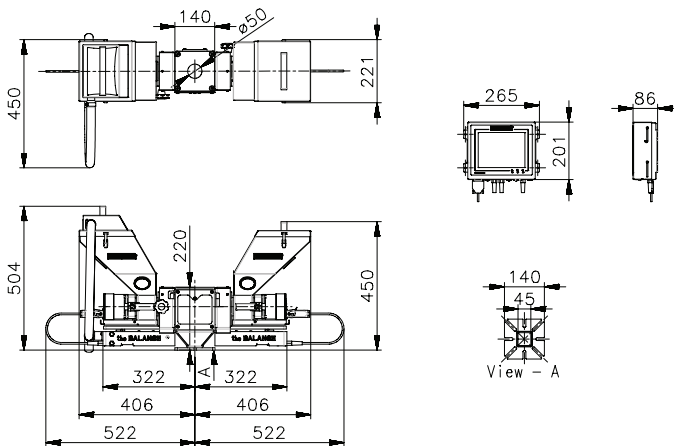

Dimensions MCS Regrind with MFD Hopper Loader

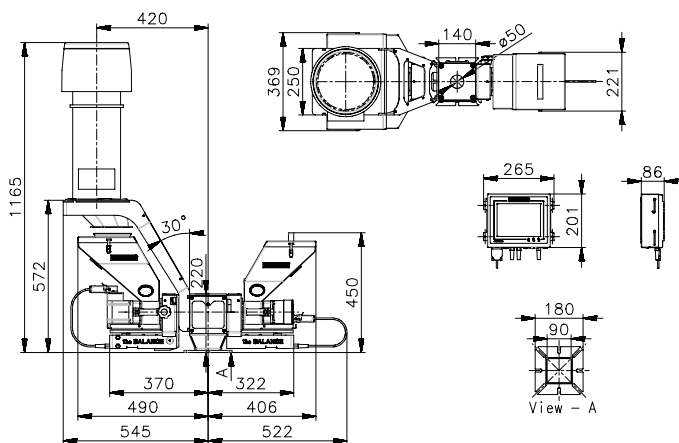

Technical Specifications

Capacity

- ▶ 0.07-180 kg/h (Depending on dosing tool fitted)
- NB. Measured with a bulk density of 0.8 kg/dm³

Applications

- ▶ Injection Moulding and Extrusion

Communication

- ▶ Modbus TCP/IP, Profibus**, Profinet**

Data Storage

- ▶ Internal memory (static changes), MCLan data logging software (dynamic changes), 500 recipes storage function

Power Supply

- ▶ 95-250 VAC, 50/60 Hz. By integrated automatic voltage selector

Power Consumption

- ▶ 300 Watt maximum

Languages

- ▶ English, German, Dutch, French, Hebrew, Turkish, Chinese, Thai, Japanese, Russian, Italian, Czech, Portuguese, Spanish, Indonesian, Polish, Korean, Hungarian, Swedish, Romanian***

Operation

- ▶ 8" full colour touch screen display

Input Signals

- ▶ Start input: potential free, 24 VDC or extruder tach (0-30 VDC)

Power Consumption

- ▶ 300 Watt maximum

Output Signals

- ▶ Alarm, warning, valve (for hopper loader control), 2x0-10 VDC** or 4-20 mA**

** optional

*** additional languages on request